

# **SG-200**

## **Installation Manual**



**ENOVAR Corporation reserves the right to make equipment changes and improvements, which may not always be reflected in this document.**

**THIS MANUAL MUST BE READ IN ITS ENTIRETY BEFORE ANY ATTEMPT IS MADE TO INSTALL OR OPERATE THE EQUIPMENT.**

#### **Proprietary Notice**

**This document contains proprietary information and such information may not be reproduced in whole or in part without written permission from:**

**ENOVAR Corporation**

**For frequently asked questions, or information on other products of ENOVAR, please visit <http://www.enovar.com>**

<b>INSTALLATION MANUAL.....</b>	<b>1</b>
<b>1 INTRODUCTION.....</b>	<b>4</b>
1.1 UNIT OVERVIEW & AVAILABLE MODELS.....	4
<b>2 SAFETY INFORMATION.....</b>	<b>5</b>
<b>3 INSTALLATION.....</b>	<b>7</b>
3.1 SYSTEM COMPONENTS.....	7
3.2 OPEN THE UNIT.....	8
3.3 CONCRETE FOUNDATION.....	8
3.4 BOLTING IT DOWN.....	8
3.5 CONDUITS.....	8
3.6 INSTALLATION OF THE GATE OPERATOR CABINET.....	9
3.7 SAFETY.....	9
<b>4 FIELD WIRING &amp; HOOKUP.....</b>	<b>9</b>
4.1 AC POWER.....	9
4.2 VEHICLE DETECTION LOOP.....	10
4.3 SIGNAL INPUTS.....	10
<b>5 LANE LAYOUTS.....</b>	<b>11</b>
5.1 MANUALLY OPERATED SINGLE- OR BI-DIRECTIONAL.....	11
5.2 MANUALLY OPENED, AUTOMATICALLY CLOSED SINGLE- OR BI-DIRECTIONAL.....	11
5.3 SINGLE DIRECTION – FREE.....	12
5.4 SINGLE DIRECTION – WITH EXTERNAL DEVICE.....	12
5.5 BI-DIRECTION – WITH ONE EXTERNAL DEVICE.....	13
<b>6 GATE ARM INSTALLATION.....</b>	<b>14</b>
6.1 STRAIGHT FLAT ARM.....	14
6.2 FOLDING ARM (FLAT).....	14
<b>7 BASIC OPERATION &amp; TEST.....</b>	<b>16</b>
7.1 OPEN GATE ARM MANUALLY.....	16
7.2 POWER ON & OPEN AND CLOSE GATE ARM.....	16
<b>8 TROUBLESHOOTING.....</b>	<b>17</b>
8.1 TO INSPECT THE MOTOR FROM THE TOP.....	17
8.2 WHEN THE BARRIER GATE DOES NOT OPERATE AT ALL.....	17
8.3 IF THE GATE ARM DOESN'T CLOSE WHEN VEHICLES DRIVE BY.....	17
<b>APPENDIX A: PARTS LIST.....</b>	<b>18</b>
<b>APPENDIX B: TYPICAL PHYSICAL LANE LAYOUT.....</b>	<b>19</b>
<b>APPENDIX C: MAINTENANCE SCHEDULE &amp; CHECKLIST.....</b>	<b>20</b>
<b>APPENDIX D: WARNING SIGN.....</b>	<b>22</b>

## 1 Introduction

Thank you for purchasing our SG-200 Parking Barrier Gate. This barrier gate has been designed for controlling the access of vehicles into and out of parking areas. To install and operate this product safely and correctly, be sure to carefully read this manual in its entirety.

### 1.1 Unit Overview & Available Models

The SG-200 gate has the following main features:

- Gate opening time: 2 second (travel time from horizontal to vertical position).
- Gate closing time: 2 seconds (travel time from vertical to horizontal position).
- The gate is typically opened by an external device or switch, and closes when a vehicle passes the closing loop.
- The gate arm will go back to the up position if a vehicle is detected on the closing loop while the arm is descending.
- Suitable for both indoor and outdoor installation, it has a 14-gauge zinc-plated steel cabinet that is powder coat painted to prevent rust.

The following types of gate arms are available:

- 10' Straight Flat Arm (part number SFB-3)
- 10' Folding Flat Arm (part number SFB-3) with Folding Arm Kit (part number SAB-H)

## 2 Safety Information

### IMPORTANT SAFETY INSTRUCTIONS

WARNING – To reduce the risk of severe injury or death:

1. READ AND FOLLOW ALL INSTRUCTIONS.
2. The gate operator is heavy (150 lbs.). Be careful when lifting or transporting it. Use proper conveying tools.
3. Always keep people and objects away from the gate. **NO ONE SHOULD CROSS THE PATH OF THE MOVING GATE.** A minimum of two (2) **WARNING SIGNS** must be installed; one on each side of the gate where easily visible.
4. Test the gate operator every month. The gate arm **MUST STOP** on contact with a rigid object, and reverse direction when an object activates the loop detection sensor. Failure to test the gate operator properly can increase the risk of injury or death. Please see Appendix C for a detailed checklist of regular maintenance that must be performed in order to guarantee safe operation of the gate.
5. Have qualified service personnel do maintenance and make repairs to all gate hardware.
6. Do not disassemble or modify the system in any way that is **NOT** described in this manual. The manufacturer and supplier shall refuse to accept liability and shall withdraw warranty cover if the system is used incorrectly or is modified in an unauthorized way.
7. All parts, housing and gate arm are designed for normal operation condition. Modifications or changes that are not described in the manual are prohibited.
8. Always make sure that the power is disconnected during installation, service or maintenance.
9. The system should be serviced by qualified personnel only. The gate operator should not be opened by non-qualified personnel, and any actions that are not described in this manual are prohibited, even if done by qualified people.
10. The manufacturer and supplier shall refuse to accept liability and shall withdraw warranty cover if the system is used without loop detector or without gate-close vehicle detection loop.
11. The gate arm should be installed completely prior to any operational tests. The gate operator is designed to work with the gate arm that is supplied. Do not lengthen or shorten the arm; do not attach anything to the arm; do not modify the arm in any way.
12. **SAVE THESE INSTRUCTIONS.**

Instruction regarding intended operation of the gate operator must be provided to the company and people that will be operating the SG-200 product.

The following instructions or the equivalent shall be provided:

#### IMPORTANT SAFETY INSTRUCTIONS

WARNING – To reduce the risk of injury or death:

1. READ AND FOLLOW ALL INSTRUCTIONS.
2. Never let children operate or play with gate controls. Keep the remote control away from children.
3. Always keep people and objects away from the gate. **NO ONE SHOULD CROSS THE PATH OF THE MOVING GATE.**
4. Test the gate operator monthly. The gate **MUST** stop on contact with a rigid object or stop when an object activates the non-contact sensors. After adjusting the force or the limit of travel, retest the gate operator. Failure to adjust and retest the gate operator properly can increase the risk of injury or death.
5. Use the emergency release only when the gate is not moving.
6. **KEEP GATES PROPERLY MAINTAINED.** Read the owner's manual. Have a qualified service person make repairs to gate hardware.
7. The entrance is for vehicles only. Pedestrians must use separate entrance.
8. **SAVE THESE INSTRUCTIONS.**

## 3 Installation

### 3.1 System Components

The system consists of the following components:

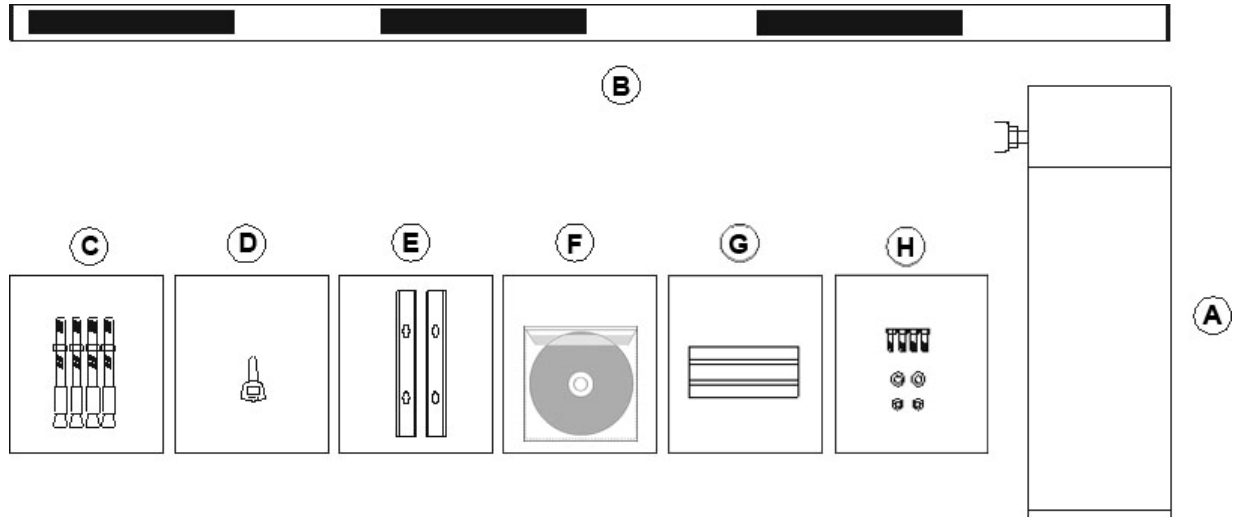

- A. Gate Operator
- B. Gate Arm
- C. Four Anchor Bolts
- D. Door Key
- E. Two Gate Fixing Rails
- F. CD-ROM with documentation (including this manual)
- G. Bar Holder
- H. Bar Holder Fixing bolts, washers and nuts

Please verify that you have all items in your possession. If the delivered goods are different, stop installation and contact your supplier immediately.

If the gate operator is intended to work with a folding gate arm, the following additional components should be in your possession. If the delivered goods are different, stop installation and contact your supplier immediately.

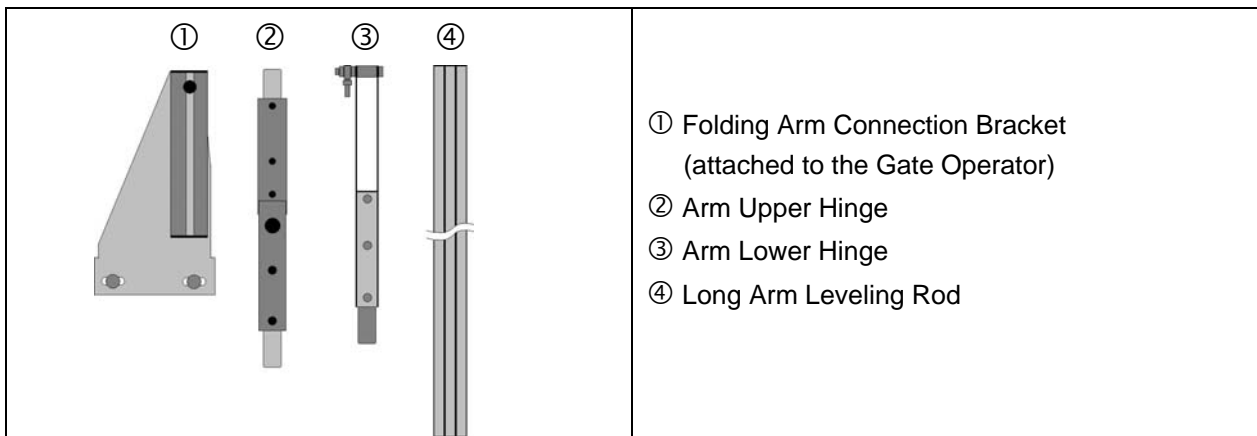

### 3.2 Open the Unit

In order to have full access to the inside of the gate, use the following procedure:

1. Use the Key (D) to unlock the door of the gate operator cabinet.
2. Pull the top of the door towards you a few inches, and lift the door out of the bottom hinge.
3. Set the door aside.
4. Unlock the white panel by pushing in the red button on the top.
5. Rotate the top of the white panel towards you and down, until the top of the panel rests on the ground.

### 3.3 Concrete Foundation

The concrete foundation onto which the gate operator is mounted should be larger than 16" x 16" x 16", in order to provide adequate weight and structure to insure stable and proper operation.

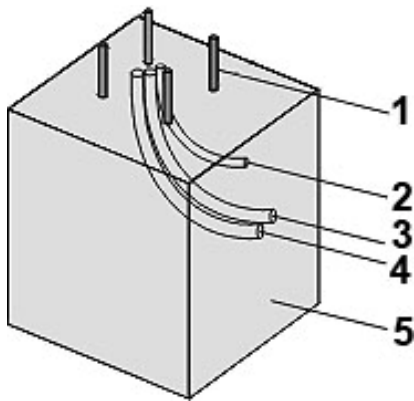

1. Anchor Bolts
2. Conduit for loop
3. Conduit for controlling signals
4. Conduit for power supply
5. Concrete

### 3.4 Bolting It Down

The gate operator should be fixed in place with the bolts and rails that are provided with it; no other bolts should be used. The anchors should be installed with approximately 2" showing above the concrete surface, in order to allow for the fixing rails and leveling adjustments and they should form a square with 7" sides, as indicated below:

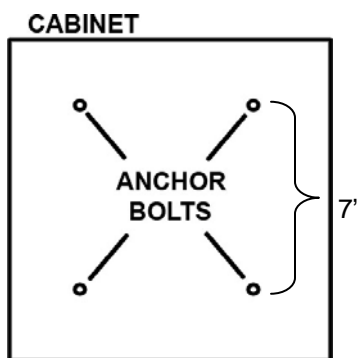

### 3.5 Conduits

Separate conduits should be provided for the main power and low voltage control wiring. Additionally, one or two extra conduits should be provided for the induction loop leads. All electric conduits should be minimum 1/2" diameter and should fit the 5.5" x 5.5" opening in the center of the cabinet. All conduits must be UL approved.

Please refer to appendix B for a physical typical layout drawing.

### 3.6 Installation of the Gate Operator Cabinet

1. Make sure the anchor bolts are fixed and tightened properly to the concrete foundation.
2. Set the gate operator housing over the anchor bolts.
3. Make sure the gate operator cabinet is level and positioned perfectly horizontal in every direction.
4. Place the gate fixing rails over the anchor bolts. Make sure the bolts are through the holes on the fixing rails, and the fixing rails cover the gate operator bottom edges by 1" on each side.
5. Place washers and nuts on the anchors and tighten.

### 3.7 Safety

Make sure induction loops are installed in accordance with instructions provided by the induction loop supplier.

After installation of the gate operator housing, confirm that the housing is mounted securely and cannot be moved anymore.

Post warning signs to properly alert pedestrians, bicycles and motorcycles about the dangers of approaching the gate. Use warning signs as provided in Appendix D.

## 4 Field Wiring & Hookup

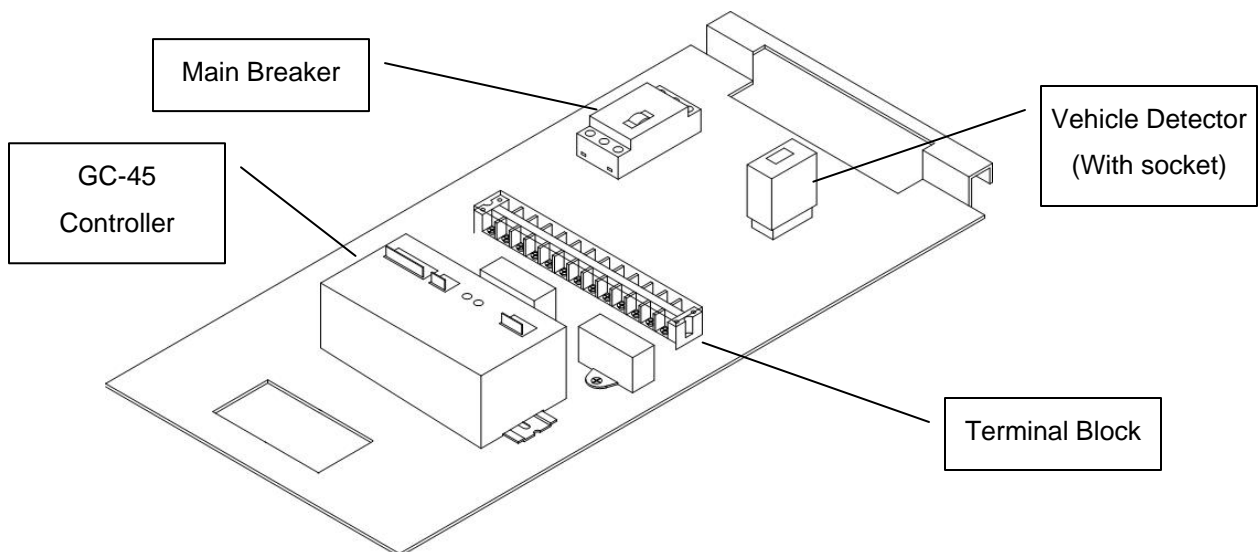

### 4.1 AC Power

1. Only use UL approved 14AWG-insulated wire.
2. Disconnect the power before proceeding.
3. Be sure your main power is OFF before attempting to hook up the AC power.
4. Run the power into the bottom of the main breaker.
5. The gate must be properly grounded and connected as required by local codes.
6. Do NOT power on and/or test the gate without the gate arm. The gate is designed to work with the gate arm, and the mechanism is calibrated accordingly. Usage without gate arm will damage the motor.

## 4.2 Vehicle Detection Loop

Connect the loop detection leads to the loop detector socket (pins 7 & 8 for PD131 single loop detector, pins 3 & 4 and 5 & 6 for PD231 dual loop detector).

Test the vehicle detection loop, and adjust its settings accordingly (sensitivity, frequency, etc.). Refer to the product documentation of the vehicle detector for proper adjustment instructions (Nortech PD131 or PD231).

## 4.3 Signal Inputs

Any external signals to remotely open the gate arm, coming from an **external** device, should be connected to the terminal block OPEN and COM.

Any external signals to remotely open the gate arm, coming from a **manually** operated switch, should be connected to the terminal block AUX and COM.

All external control devices must have **normally open** dry contacts.

The GC-45 unit contains the following LED's:

- a. OPEN: LED is on when receiving a signal on the OPEN connection
- b. CLOSE: LED is on when receiving a signal on the CLOSE connection
- c. AUX: LED is on when receiving a signal on the AUX connection
- d. POWER: lights up when the main power is received and the fuse is operational

The controller also contains a 'Mode LED' and a pushbutton mode switch.

The Mode LED will indicate the status of the controller.

Confirm the following behavior to make sure the gate is operating properly:

- a. When the gate is powered on, the LED will blink for 3 seconds at 5Hz
- b. When the gate is idle, ready to accept external open signals, the LED blinks permanently at 1Hz
- c. During motor operation, to open or close the gate arm, the LED is off.
- d. After the gate has been opened with the mode switch, the LED is on.

When pressing the mode switch once, the gate arm will ignore all external signals, and open. The mode LED will turn on.

When the mode switch is pressed again, the gate will resume normal operation, and close (if no external signals prevent it from closing). The Mode LED will resume blinking at 1Hz (one time per second).

## 5 Lane Layouts

### 5.1 Manually Operated Single- or Bi-Directional

**Lane operation:** The gate is manually controlled by an external switch and there are no loops to detect vehicles. A remote operator activates a switch to raise the gate arm, and releases the switch to lower the gate arm. Cars can potentially drive in either direction.

**Typical Lane Layout:**

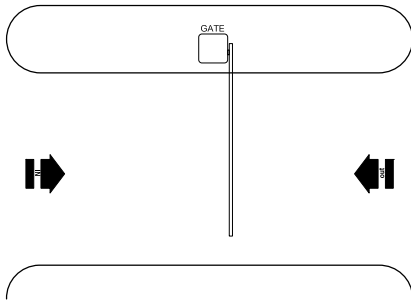

**Wiring:**

Connect the remote switch to AUX and COM

### 5.2 Manually Opened, Automatically Closed Single- or Bi-Directional

**Lane operation:** The gate is manually controlled by an external switch and there is a closing loop to detect vehicles as they pass through, in order to lower the gate arm. A remote operator activates a switch to raise the gate arm. The Closing loop detects when the car drove through the lane, after which the gate arm is lowered. Cars can potentially drive in either direction.

**Typical Lane Layout:**

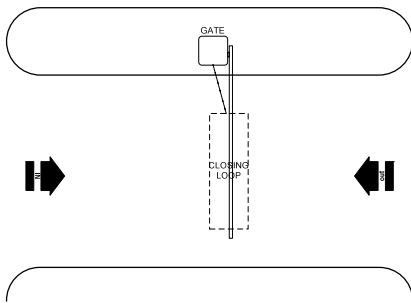

**Wiring:**

Connect the remote switch to AUX and COM

Connect the signal from the Closing Loop Detector to CLOSE and COM

### 5.3 Single Direction – Free

**Lane operation:** The Opening loop detects an approaching vehicle, and will activate the signal to raise the gate arm. The Closing loop detects when the car drove through the lane, after which the gate arm is lowered. Cars can only drive in one direction.

#### Typical Lane Layout:

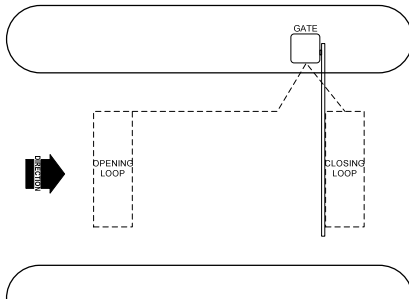

#### Wiring:

Connect the signal from the Opening Loop Detector to OPEN and COM  
 Connect the signal from the Closing Loop Detector to CLOSE and COM

### 5.4 Single Direction – With External Device

**Lane operation:** The gate is controlled by an external device (e.g. card reader). There is an optional reader-arming loop, and there is a closing loop. The external device activates the gate-open signal, and the gate-closing loop detects when the car drove through the lane, after which the gate arm is lowered. Cars can only drive in one direction.

#### Typical Lane Layout:

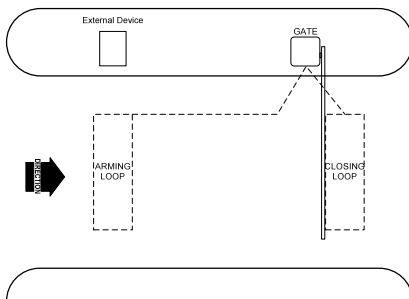

#### Wiring:

Connect the signal from the Arming Loop Detector to the external device (optional)  
 Connect the open-signal from the external device to OPEN and COM  
 Connect the signal from the Closing Loop Detector to CLOSE and COM

## 5.5 Bi-Direction – With One External Device

**Lane Layout:** The gate is controlled by an external device (e.g. card reader) in one direction and by an inductive loop in the other direction. There is an optional reader-arming loop, and there is a closing loop.

- For IN-direction: The external device activates the gate-open signal, and the gate-closing loop detects that the car drove through the lane, after which the gate arm is lowered.
- For OUT-direction: The free loop detects an approaching vehicle, and will activate the signal to raise the gate arm. The Closing loop detects that the car drove through the lane, after which the gate arm is lowered.

### Typical Lane Layout:

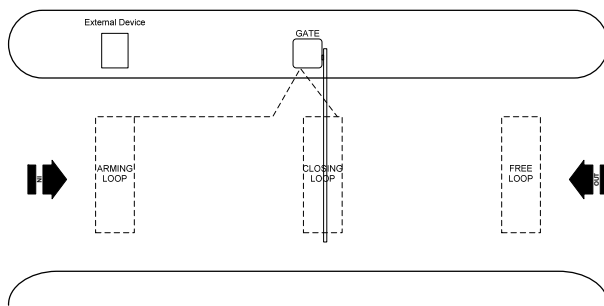

### Wiring:

Connect the signal from the Arming Loop Detector to the external device (optional)

Connect the signal from the Closing Loop Detector to CLOSE and COM

Connect the signal from the Free Loop Detector AUX and COM

## 6 Gate Arm Installation

Do NOT attach anything to the Gate Arm. Additional attachments, such as stop signs, warning boards or lights may cause unexpected trouble, and interfere with safe operation of the system.

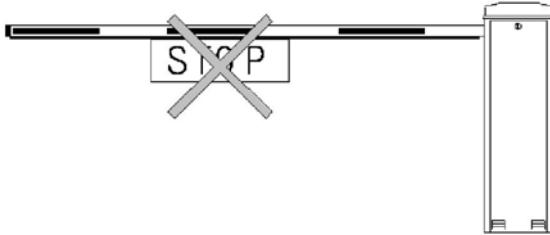

### 6.1 Straight Flat Arm

Attach the arm to the arm holder by sliding it all the way into the holder, and by fixing the two screws on the bottom of the holder.

Attach the Arm Holder to the Gate Operator with the four (4) bolts, washers and nuts supplied with it.

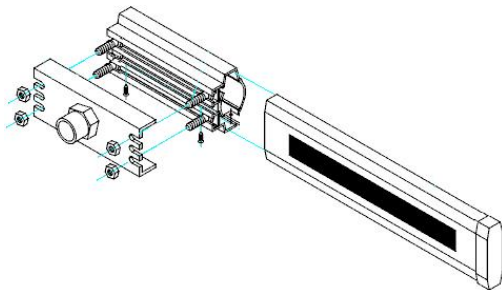

### 6.2 Folding Arm (Flat)

Refer to separate instructions to cut the folding arm at the desired length.

Remove the top cover of the gate operator (See Section **Error! Reference source not found.**)

Drill two 21/64" holes in the main housing in the following location:

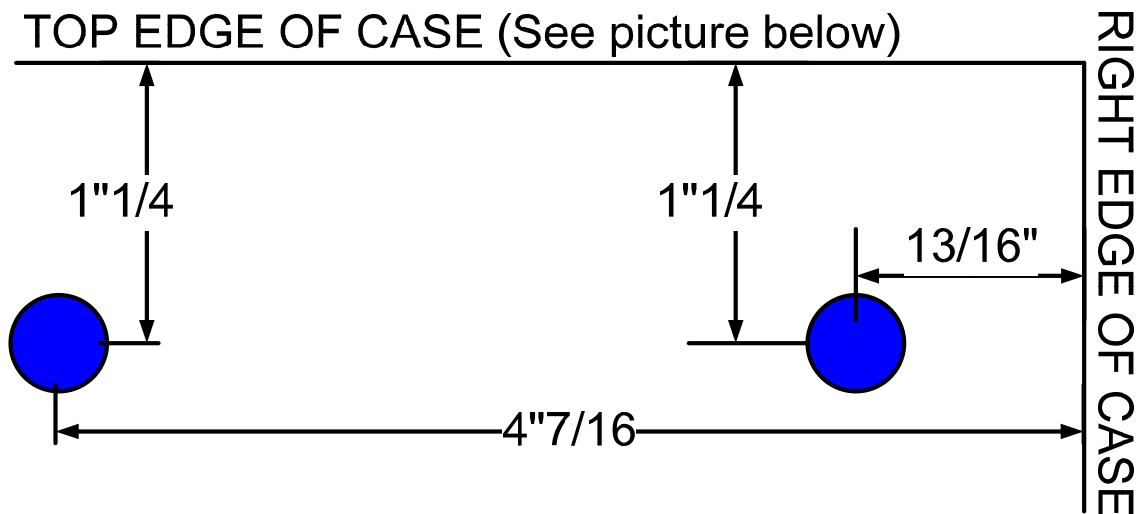



Treat these newly drilled holes against corrosion, and use them to mount the folding arm bracket. The result of this modification should look as follows:



Follow the instructions of '6.1 Straight Flat Arm' to attach the Arm Holder to the first part of the arm. Attach the second part of the Arm to the Hinge and to the first part of the arm. Cut the leveling rod at desired length, and attach it to the Arm Hinge and to the Gate Cabinet.

## 7 Basic Operation & Test

### 7.1 Open Gate Arm Manually

After the gate arm is mounted, the movement of the gate arm can be tested WITHOUT powering on the unit. THIS PROCEDURE CAN ALSO BE USED IN CASE OF POWER FAILURE. MAKE SURE YOU PRACTICE THIS PROCEDURE, AND MAKE SURE THE AUTHORIZED LOCAL STAFF IS ALSO TRAINED TO PERFORM THIS OPERATION.

1. Make sure the unit is powered OFF.
2. Turn the manual lever (the handle for the safety lock) about 15 degrees anti-clock-wise while applying slight upward pressure on the gate arm itself.



3. After about 15 degrees, the gate arm can be raised by hand, all the way up

### 7.2 Power ON & Open and Close Gate Arm

After all items in sections 3, 4 and 6 have been successfully completed, turn the power on, by switching the main breaker ON.

WAIT UNTIL THE LED ON THE CONTROLLER STOPS BLINKING FAST, AND STARTS BLINKING AT 1 HZ (ONCE PER SECOND).

Push the small button (Mode button) on bottom right of the GC-45 controller once to raise the gate arm, and push it again to lower the arm and return to its normal operation.

If you have external devices or arming loops connected, carefully test them one by one, and make sure the gate operates as expected.

FOR TESTING THE GATE WITHOUT VEHICLE DETECTION LOOP: REMOVE THE LOOP DETECTOR FROM THE SOCKET (otherwise, the system will sense a vehicle on the closing loop, and the arm will never close).

## 8 Troubleshooting

### 8.1 To inspect the motor from the top

If you would like to inspect the movement of the motor from the top, you can remove the top cover of the gate operator. This is done by removing two wing nuts that are located towards the top of the gate operator cabinet on two sides of the motor, and can be reached through the door. Make sure the unit is powered off while attempting to remove the cover. Make sure the cover is mounted and fixed again after inspection.

### 8.2 When the barrier gate does not operate at all

1. Check the incoming power.
2. Check the fuse. If broken, replace the failed fuse.
3. Check the mode LED.
  - If the LED is permanently on, the wrong signals from external sensors, manual switches, or vehicle detector is continuously being received. Check these external devices, and repair if necessary.
  - If the LED is permanently off, replace the controller and check the system again.
4. Check the status of all connections, looking for potentially loose or intermittent connections.

### 8.3 If the gate arm doesn't close when vehicles drive by

1. Check the power first and reset the power.
2. Check the vehicle detector LED when a vehicle crosses the loop. The LED should be on if while the vehicle is on the loop. If it is not, check the loop wiring and/or replace the loop detector.
3. Make sure none of the OPEN or AUX LED's are permanently on. If they are, check the external devices that provide these signals.
4. Check the CLOSE LED on the controller. The LED should be on if while the vehicle is on the loop. If it is not, make sure the LED on the vehicle detector behaves normal, and, if it does, replace the controller. If the LED on the vehicle detector does not operate as expected, replace the detector and/or inspect the induction loop.
5. FOR TESTING THE GATE WITHOUT VEHICLE DETECTION LOOP: REMOVE THE LOOP DETECTOR FROM THE SOCKET (otherwise, the system will sense a vehicle on the closing loop, and the arm will never close).

## Appendix A: Parts List

The following table gives a list of the parts that can be ordered separately

Part Number	Description
SG-200-Case	Top cover, main case and external door, with key lock
SG-200-WhitePanel	White internal door panel with all controlling components
GC-45	GC-45 controller
PD-131	Single channel loop detector
SFB-3	Flat gate arm (10')
S&B-45	Octagonal gate arm (15')
SAB-H	Folding arm kit (to be used together with SFB-3)
SG-200-Motor	The total motor assembly, including the springs and arm rotator

## Appendix B: Typical Physical Lane Layout

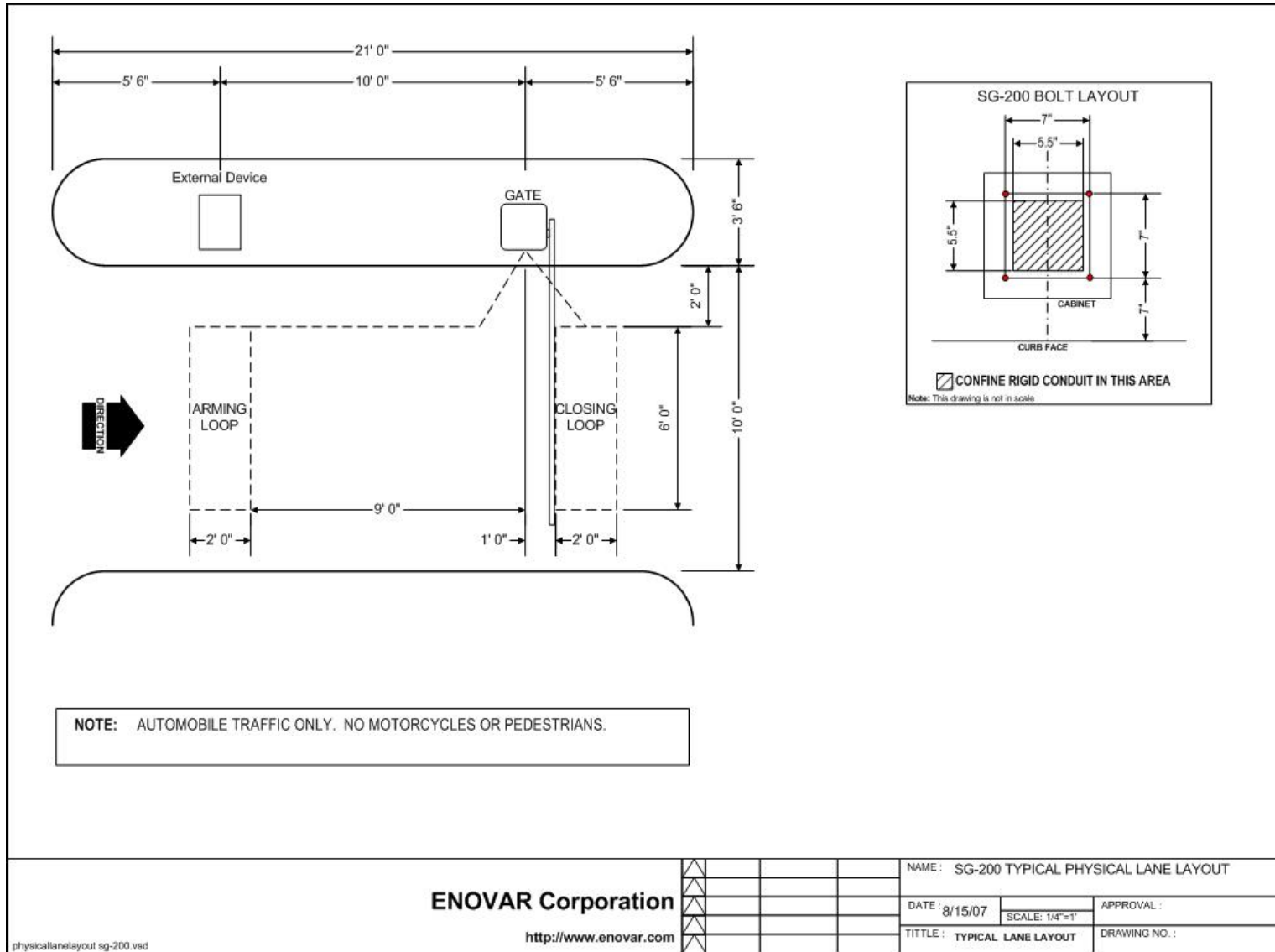

## Appendix C: Maintenance Schedule & Checklist

### Regular Maintenance Schedule

Procedures	Maintenance Intervals (Every Month or 50,000 Gate Cycles)
Check the Alignment of the Arm	✓
Check all Connections	✓
Check the Loop Function	✓
Inspect the Motor	✓
Perform the Auto Stop Function (check that the gate arm reverses direction when the gate closing loop detects a metal object while the gate arm is going down)	✓



**Appendix D: Warning Sign**

(This page is intentionally left blank; see next page for the warning sign)



# WARNING

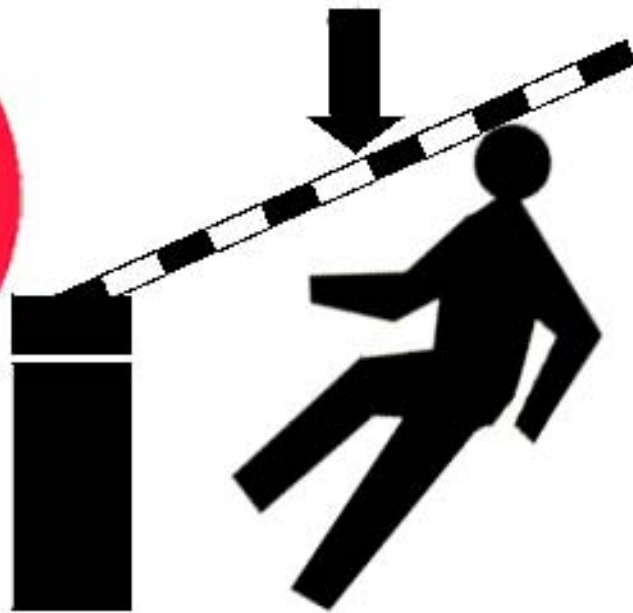

## Moving Gate Can Cause Injury Or Death

- 1) Persons are to keep clear! The gate is able to be moved without prior warning.
- 2) Do not let children operate the gate or play in the gate area.
- 3) Persons are to operate the gate only when the gate area is in sight and free of people and obstructions.
- 4) This entrance is for vehicles only. Pedestrians must use separate entrance.
- 5) Bicycles and Motorcycles must use separate entrance.